

13-009

Originele naam: Shafiei V

Eurocircuits referentie: E554674

Bijzonderheden: 56,5x35mm, 4 layer, Maskers aanwezig

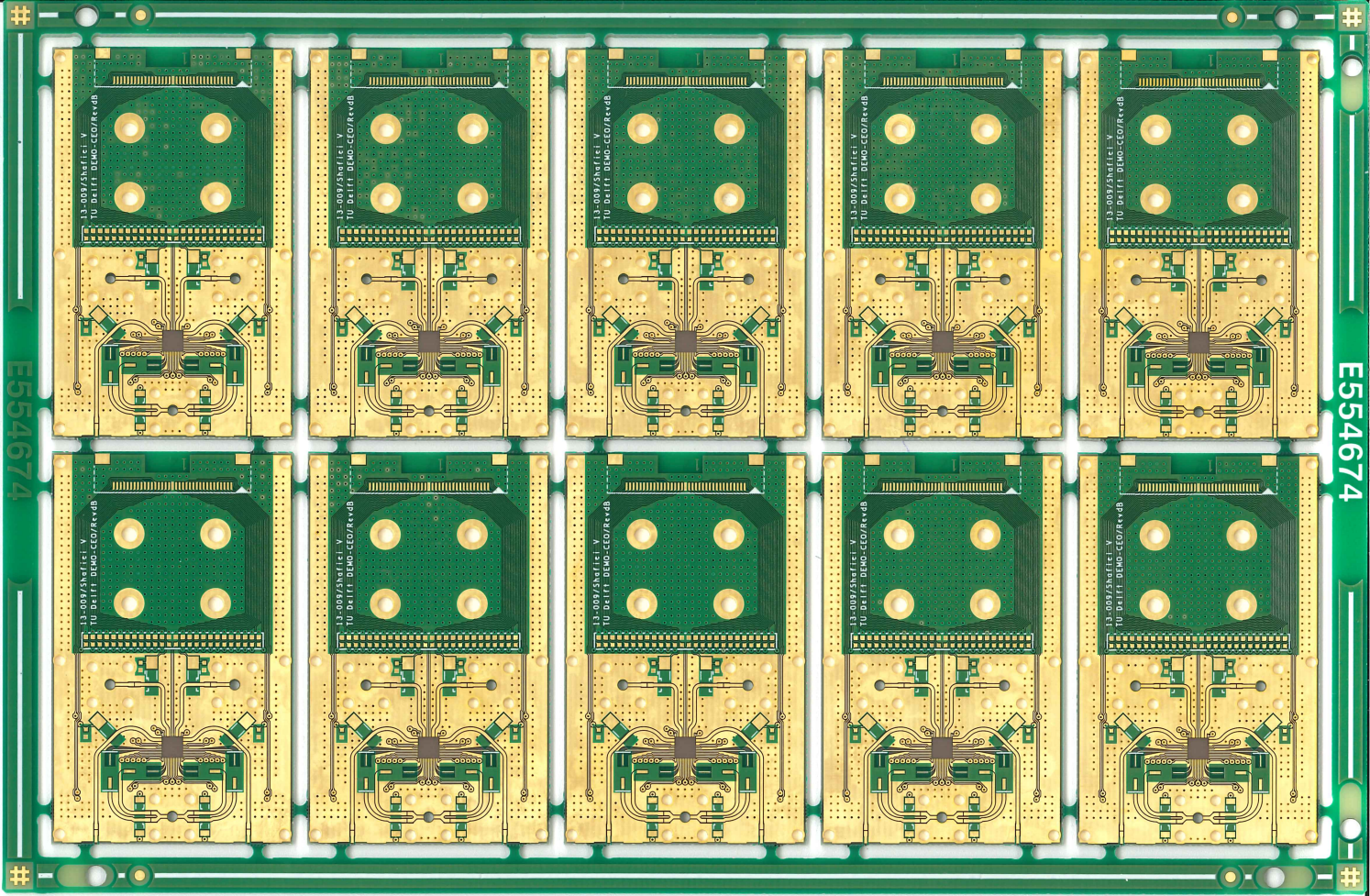

E554674

E554674

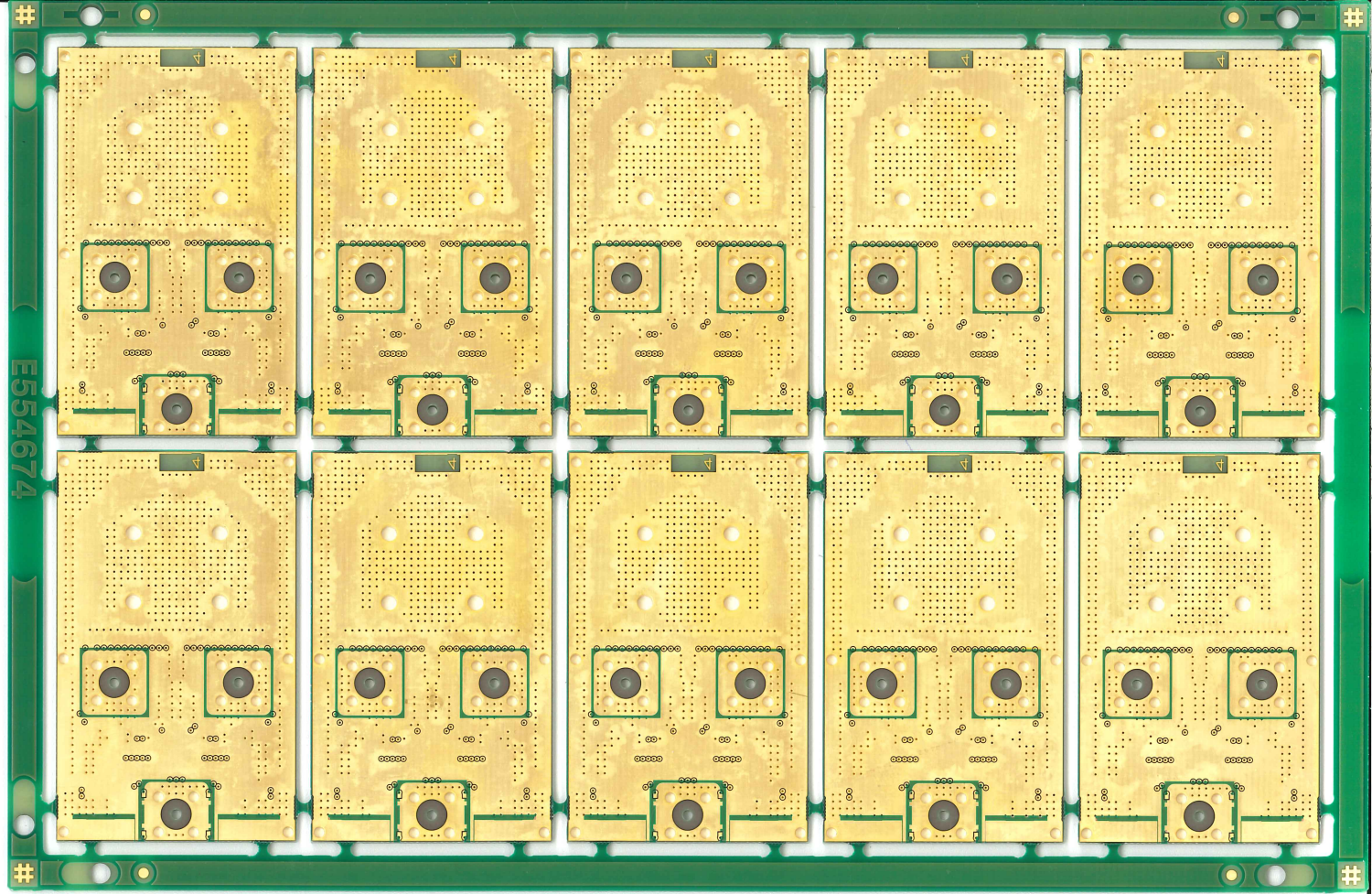

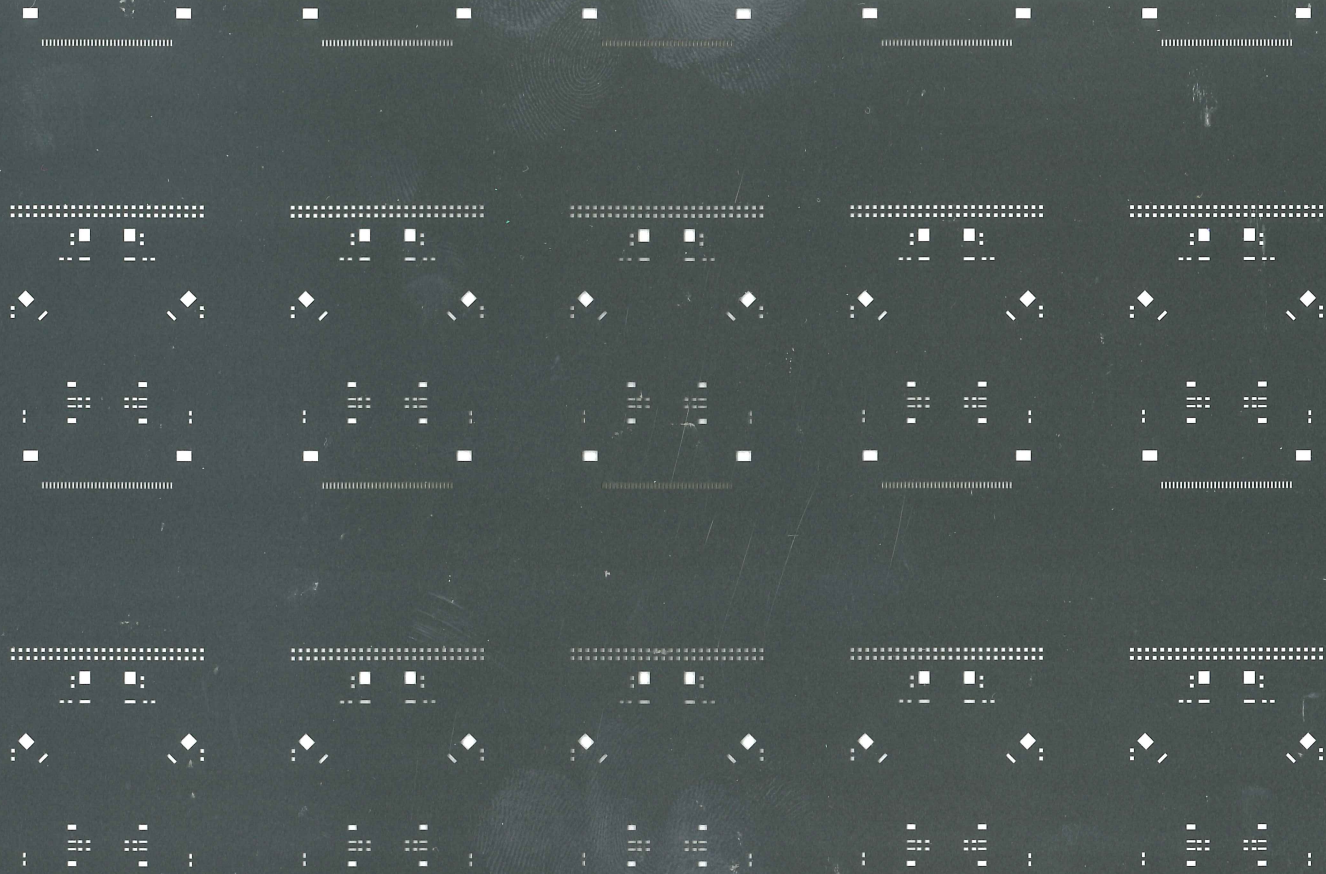

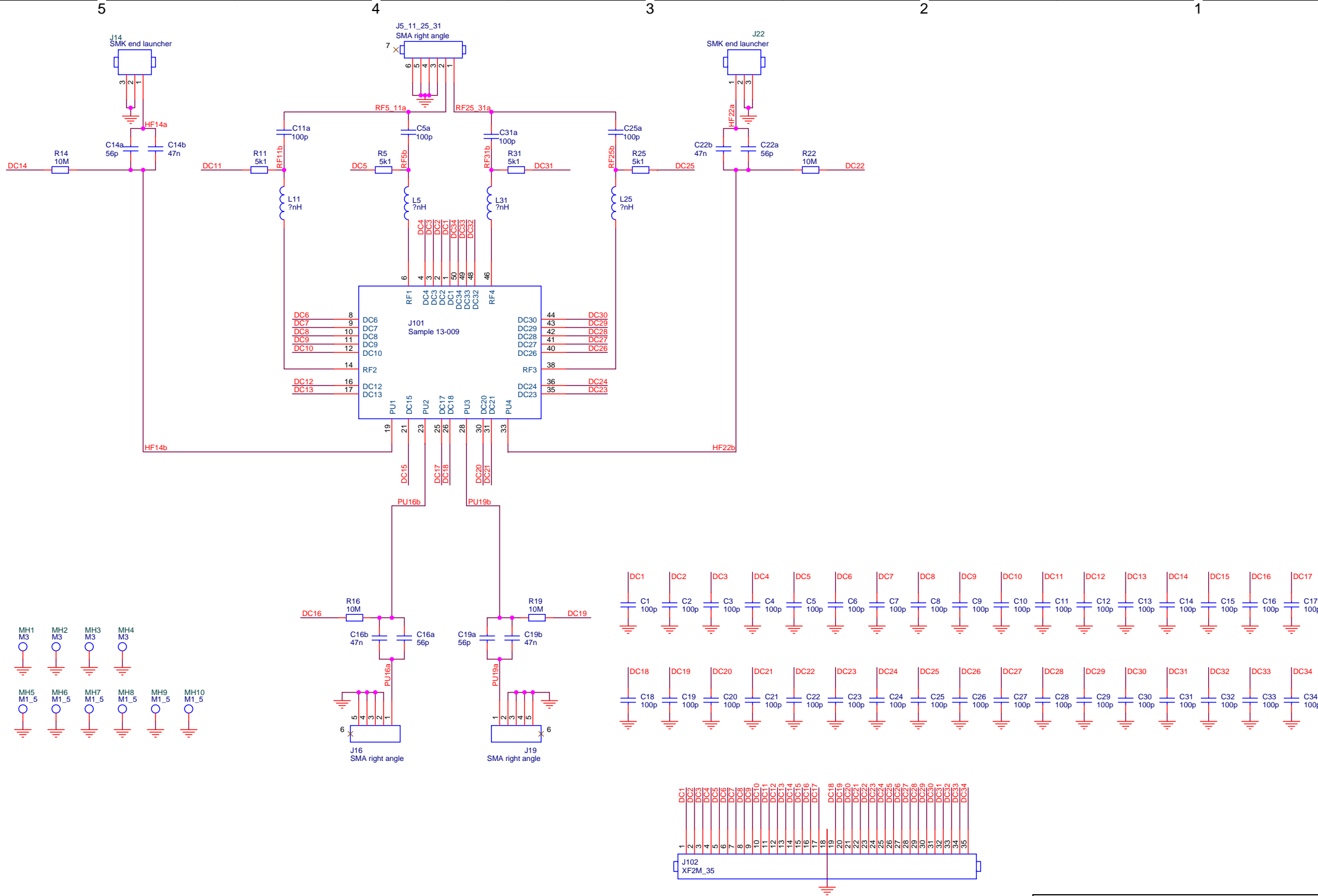

Title		
Sample Board Shafiel V		
Size	Document Number	Rev
A3	13-009	A
Date:	Thursday, March 28, 2013	Sheet 1 of 1

E554674 PCB view TOP (topview)

E554674

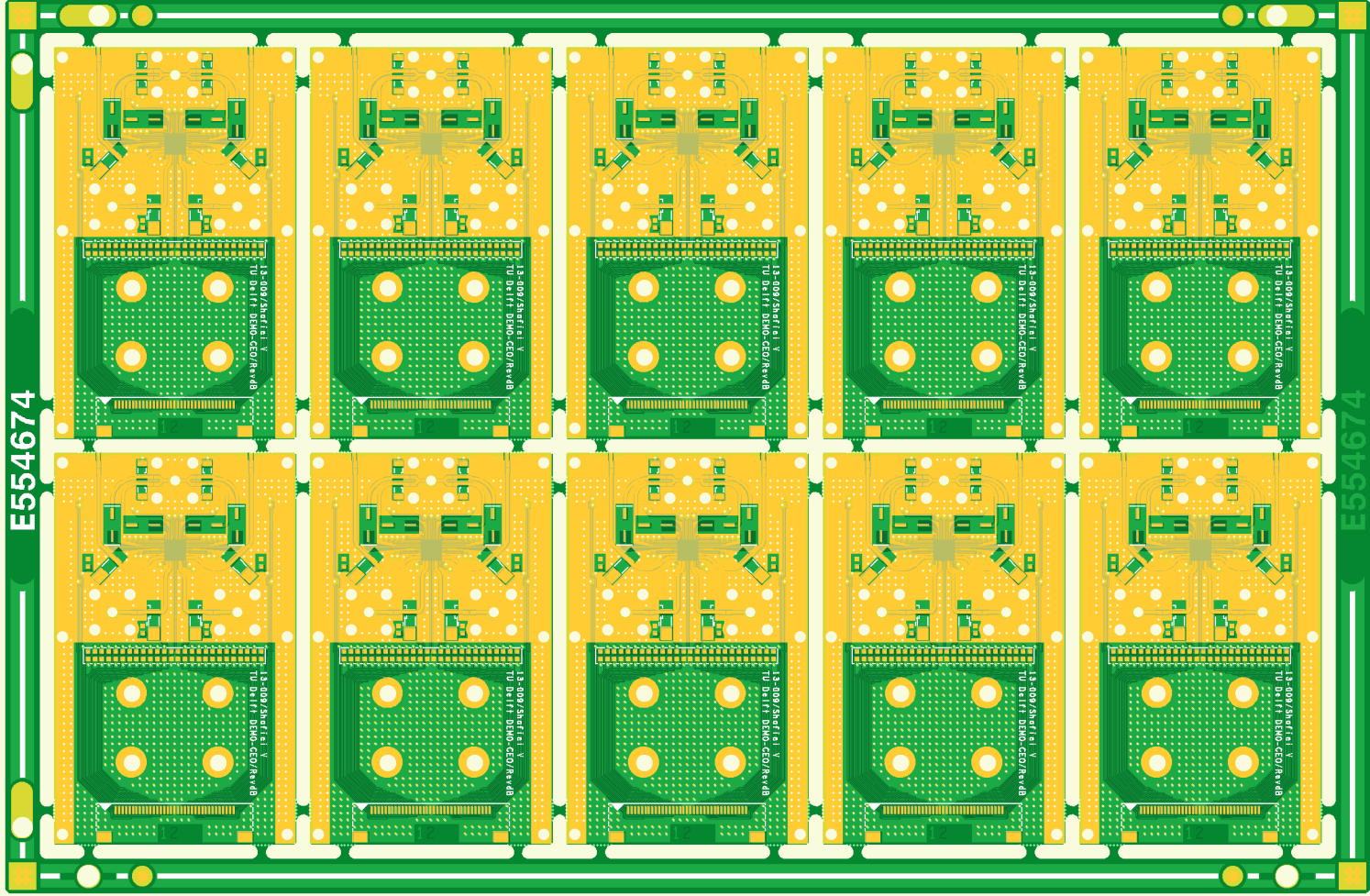

E554674

E554674 TOP layer Image (topview)

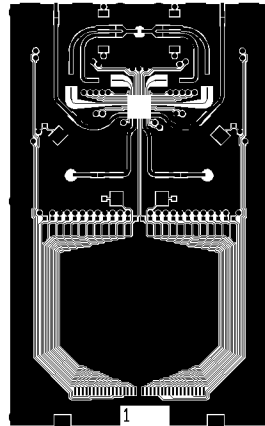
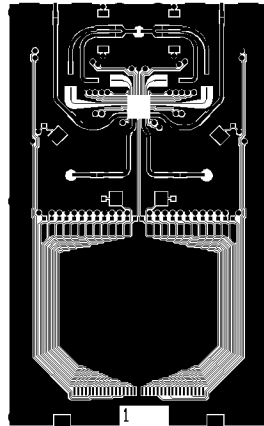
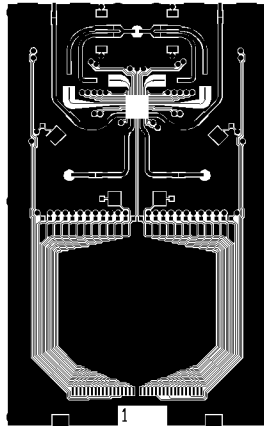
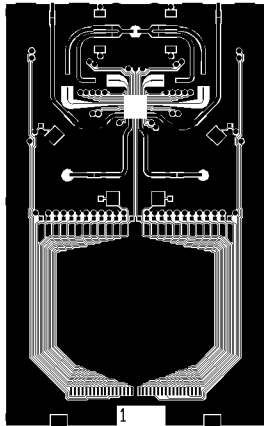
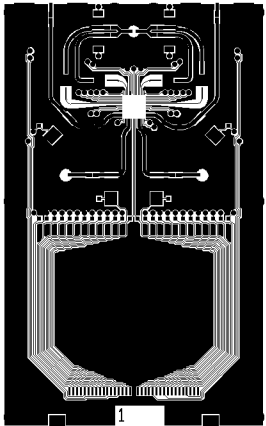
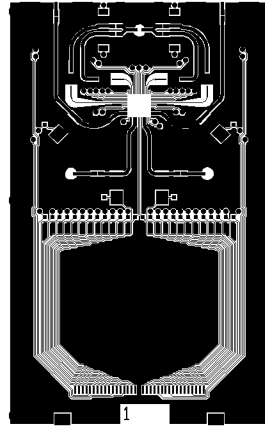
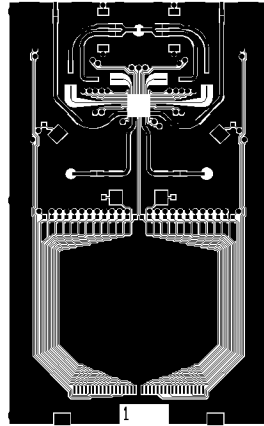
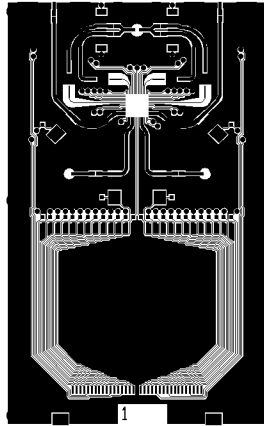
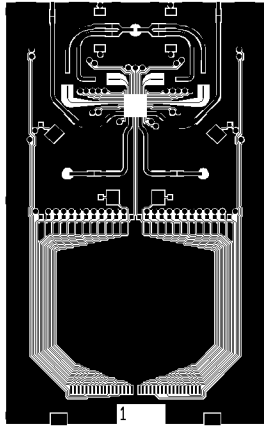
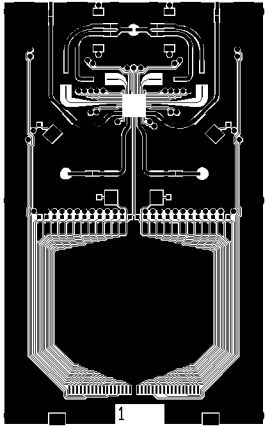

E554674

E554674 Innerlayer 2 Image (topview)

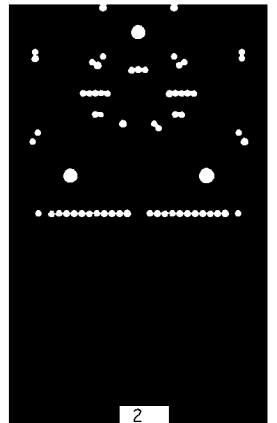
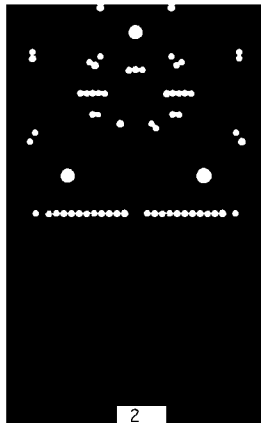
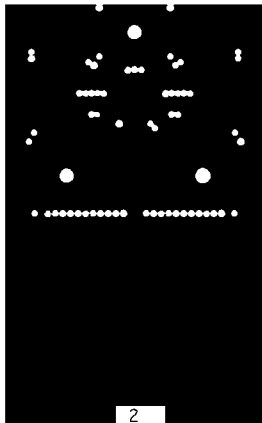
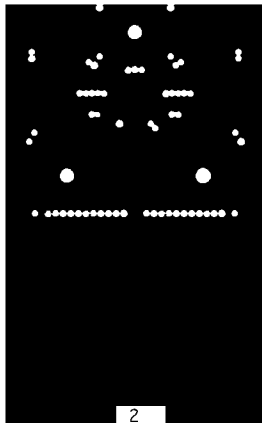
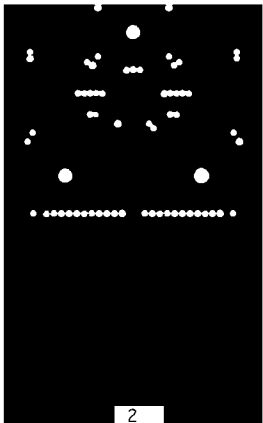
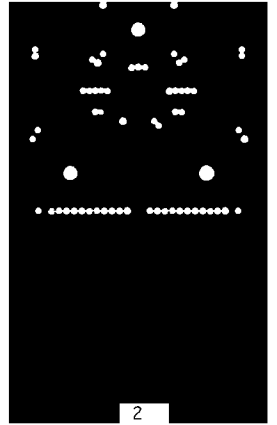
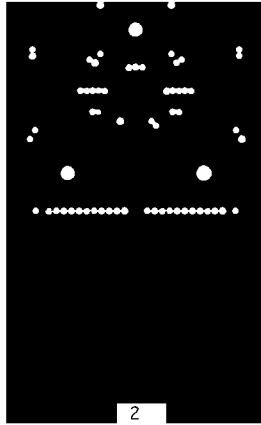
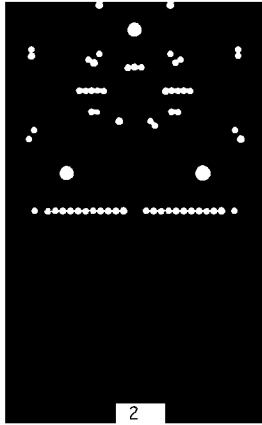
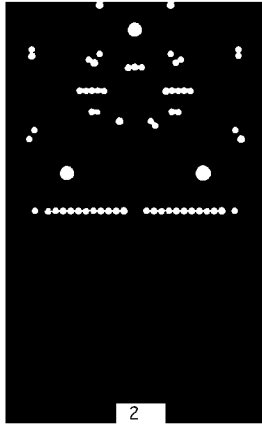
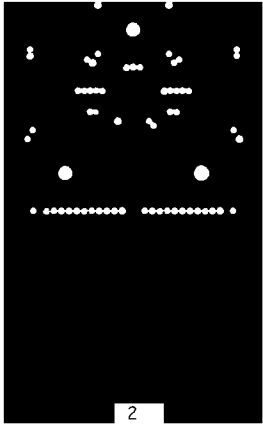

E554674 Innerlayer 3 Image (topview)

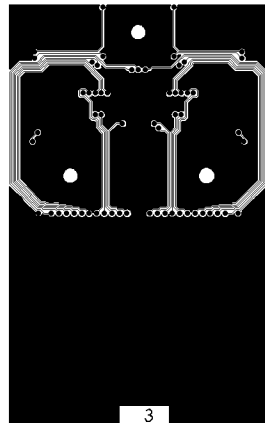
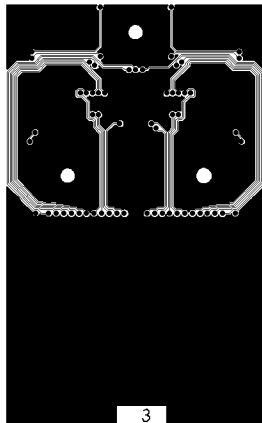
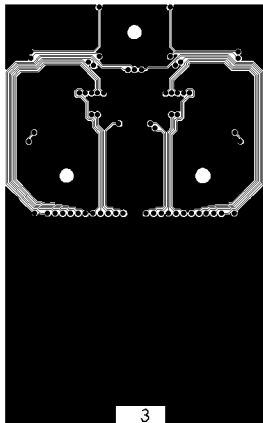
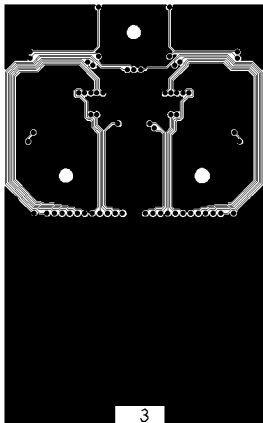
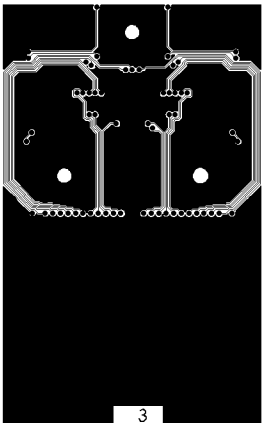
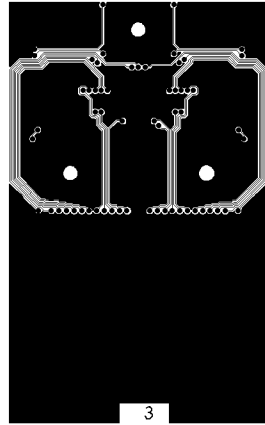
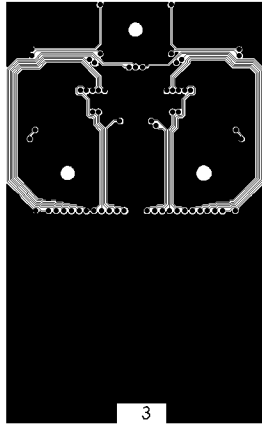
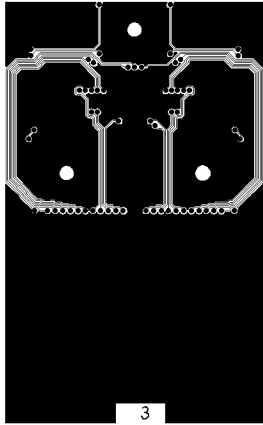
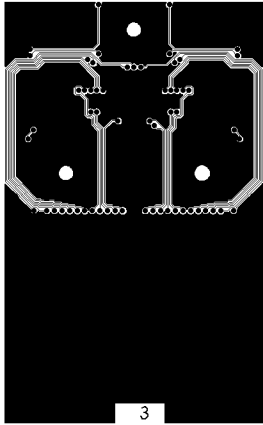
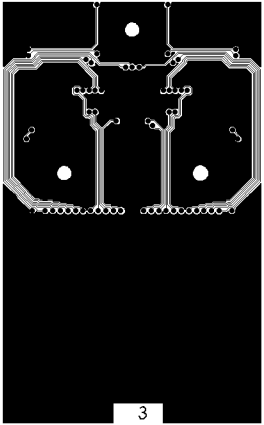

E554674 BOTTOM layer Image (topview)

#

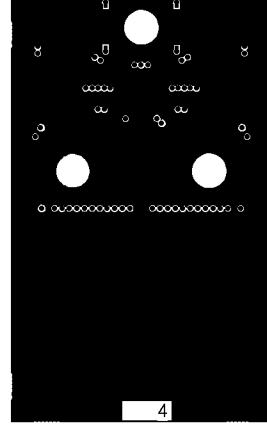
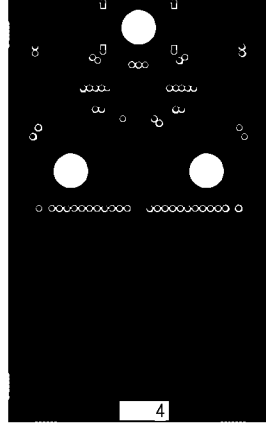
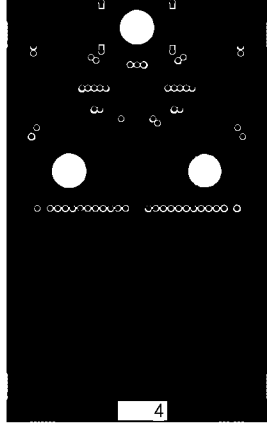
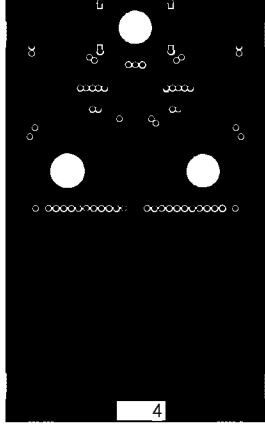
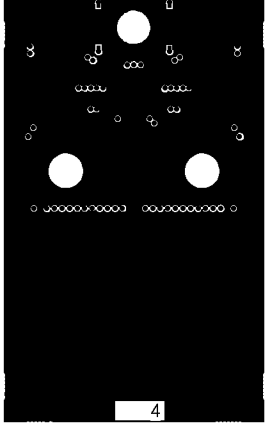

4704234

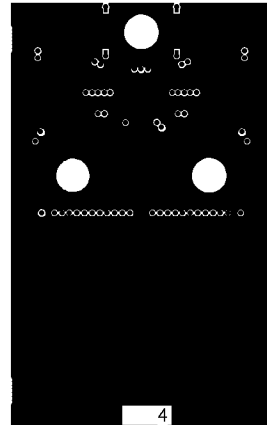
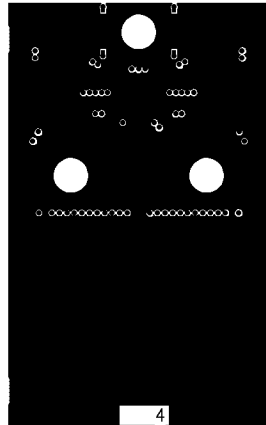
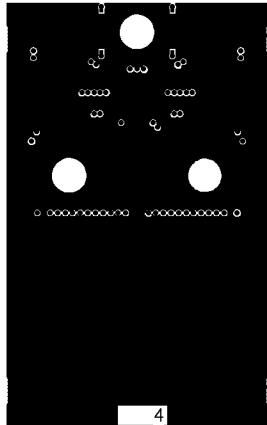
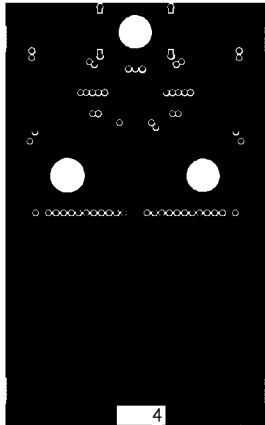
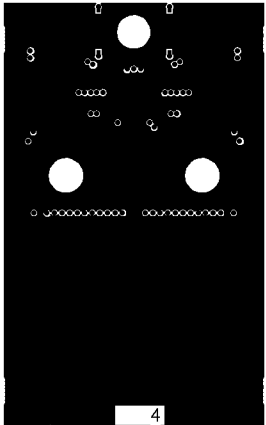

#

#

E554674 PCB view BOTTOM (bottomview)

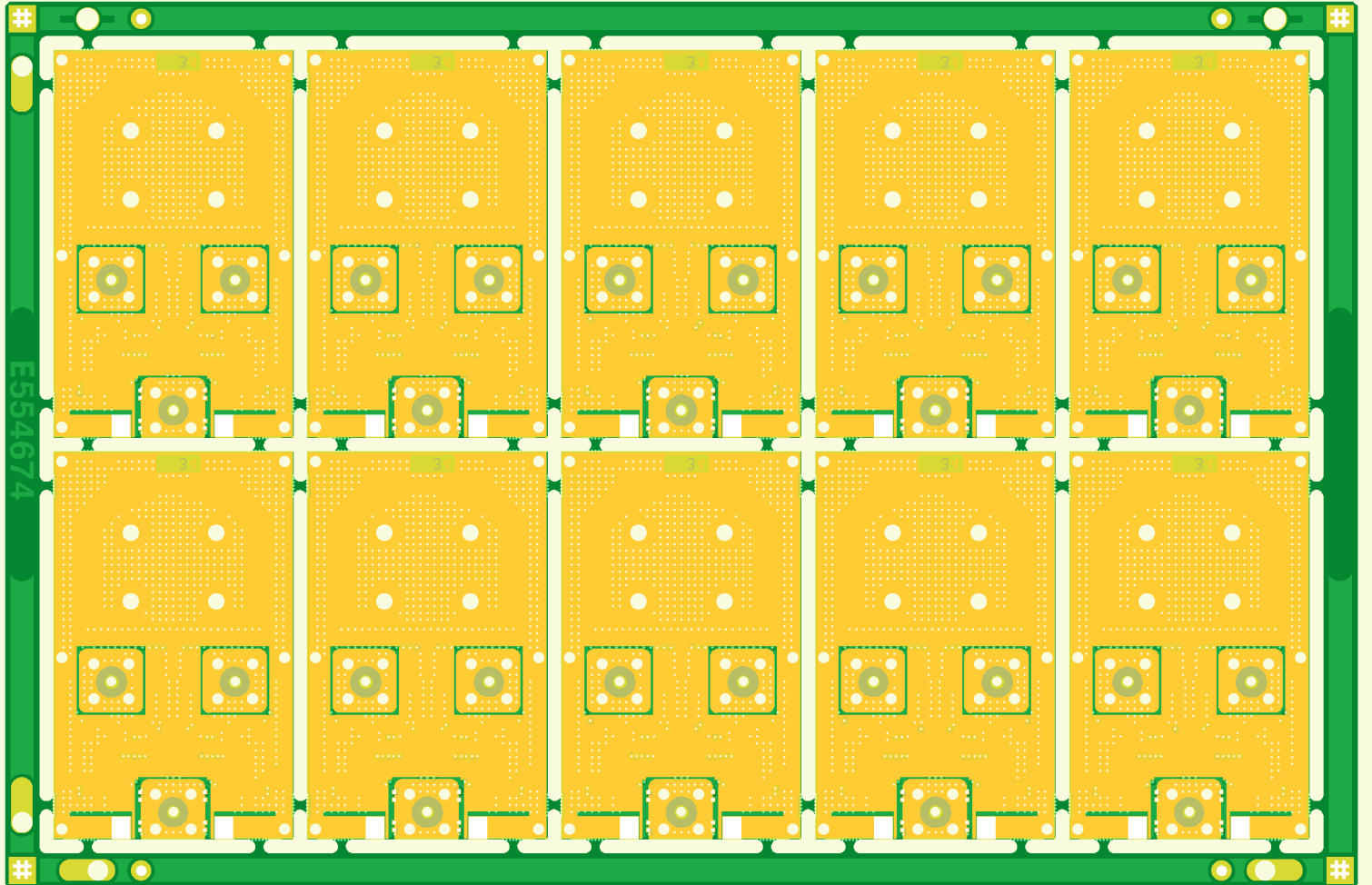

E554674 PCB Mechanical view (topview)

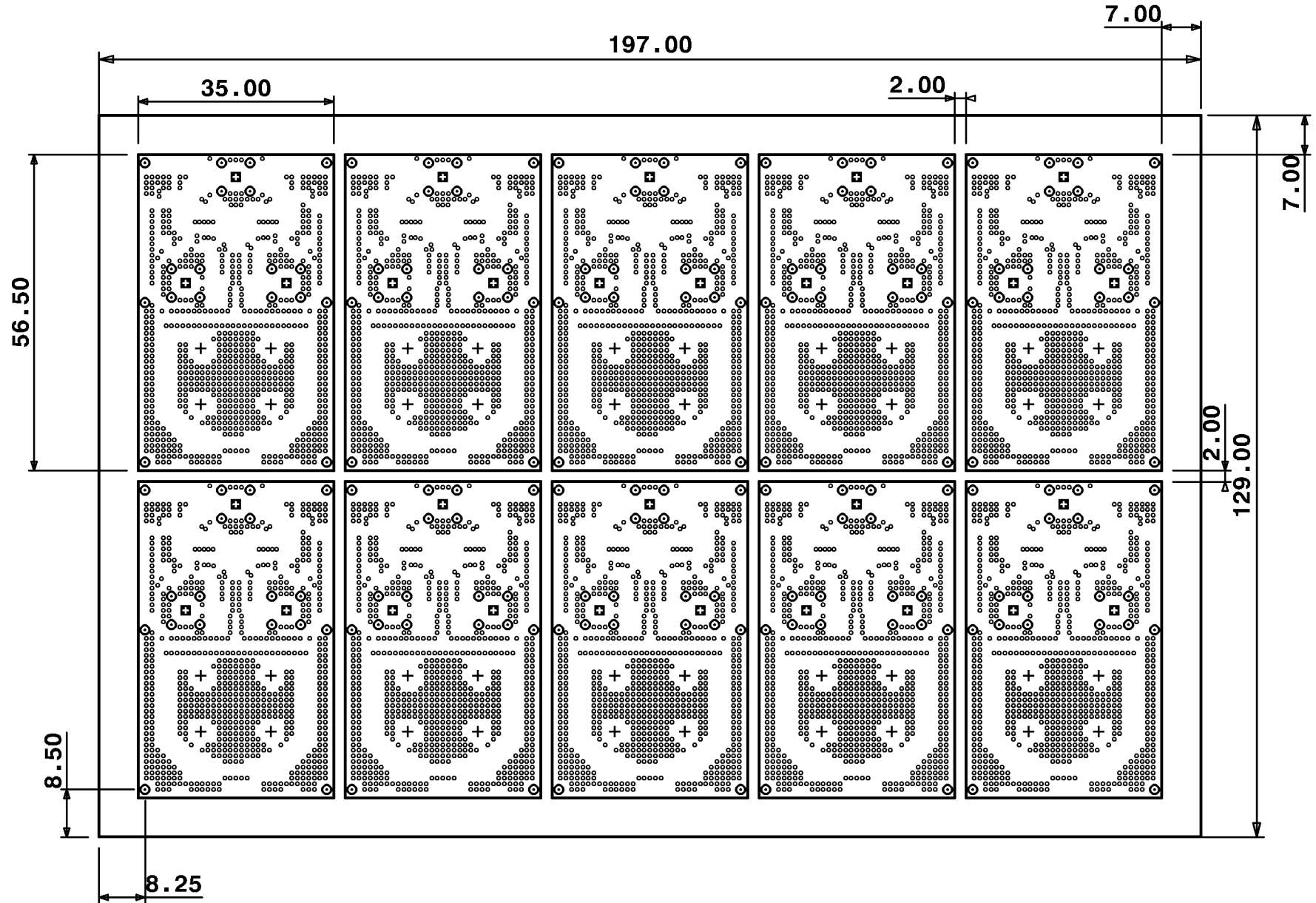

Drill Report : Layer E554674-60

Symbol	END.dia (mm)	ToolDia (*0.01mm)	number of Holes	spec.desc. Nibb(N) mill(M)	NPTH	Made by: Malay Patel
°	0.25	35	7320	0		Date: 2013 05 17
■	1.40	145	30	0	X	File: E554674
○	1.50	165	180	0		
+	2.20	235	40	0		

IN 70 RUN

